

Features

- Quad flat pack (QFP) carriers protect fragile leads on QFP devices during shipping and device handling.
- QFP development sockets allow on-board electrical and mechanical prototype testing with QFP packages.
- Carriers and development sockets are available for 100-, 160-, 208-, 240-, and 304-pin devices.
- Development socket footprints are compatible with QFP footprints, providing a smooth transition from prototype to production.
- Together, carriers and sockets help prevent electrostatic damage to the devices while providing excellent AC circuit performance.

General Description

Altera QFP carriers and development sockets protect the fragile leads on QFP devices during shipping and throughout the development cycle. Each socket is designed with a lead footprint that is compatible with the device, so it can be used during both mechanical and electrical prototyping. QFP carriers and development sockets are currently available for 100-, 160-, 208-, 240-, and 304-pin QFP packages. **Figure 1** shows the carrier and development socket for the 100-pin QFP device (the 160- and 208-pin QFP carriers and development sockets are similar).

Figure 1. 100-Pin QFP Carrier & Development Socket

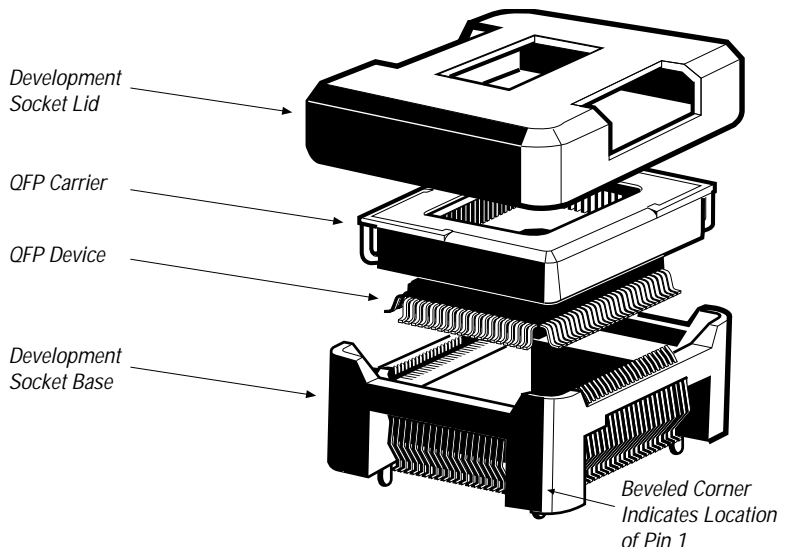
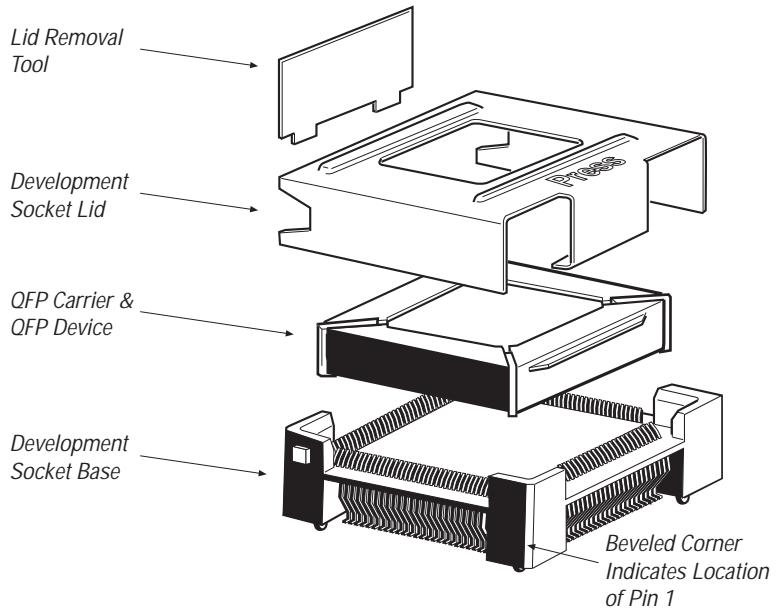

Figure 2 shows the carrier and development socket for the 240-pin QFP device (the 304-pin QFP carrier and development socket are similar).

Figure 2. 240-Pin QFP Carrier & Development Socket



QFP Carrier

The carrier is a static-dissipative, molded plastic shell that holds the QFP device in a secure frame to prevent mechanical damage to the device leads. The device is held in the carrier by recessed plastic clips (two clips on the 100-pin carrier and four clips on the 160-, 208-, 240-, and 304-pin carriers). Figure 3 shows the dimensions of the QFP carriers.

All MAX 9000, MAX 7000, and MAX 5000 QFP devices with 100 to 304 pins can be ordered in carriers, which eliminates the need to handle the delicate device leads. The devices and carriers are packaged in antistatic rails.

Devices can be programmed and erased while in the carrier. EPROM-based QFP devices are erased with a UV lamp; EEPROM-based QFP devices are erased electrically in a programming adapter.



QFP devices without protective carriers should be handled with a vacuum wand in an electrostatically protected workplace to reduce the possibility of mechanical or electrical device damage.

Figure 3. QFP Carrier Dimensions

Dimensions are shown in millimeters. The carrier is rated from -65°C to 155°C , and is qualified to handle commercial and industrial operating temperatures. Illustrations are not drawn to scale.

100-Pin QFP Carrier

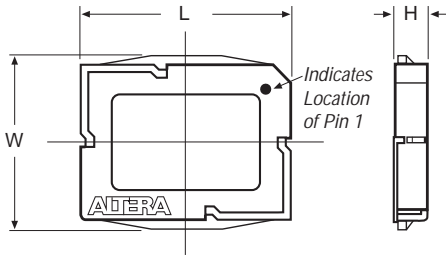

160- & 208-Pin QFP Carrier

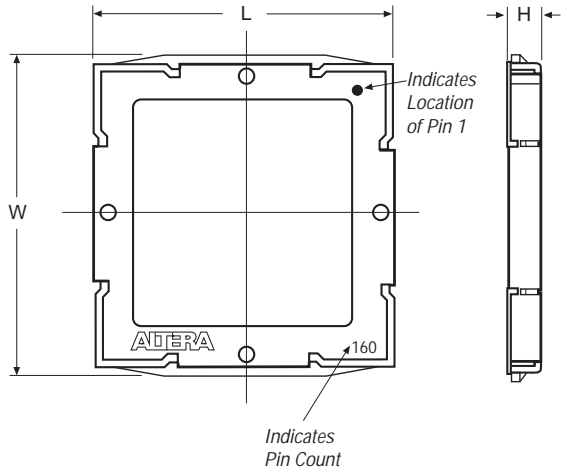

240- & 304-Pin QFP Carrier

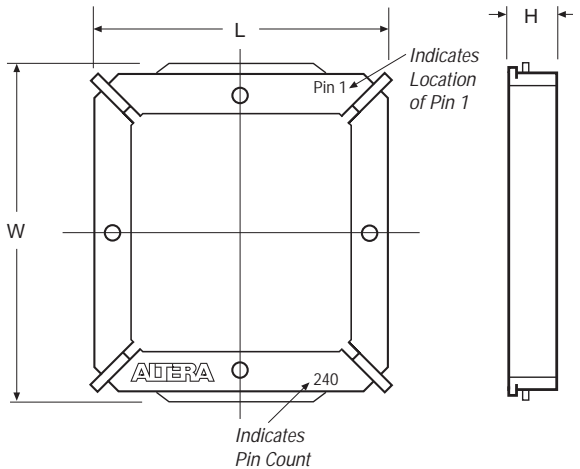

Pin Count	L	W	H
100	25.2	21.2	4.2
160	33.2	35.2	5.1
208	33.2	35.2	5.1
240	37.0	40.0	6.4
304	45.0	48.0	6.4

QFP Development Socket

The QFP development socket footprint is compatible with the lead footprint of the QFP device. The socket ensures the device's electrical connection to the printed circuit board (PCB) and provides excellent AC circuit performance, including low noise, low capacitance, and low inductance. Although the QFP development socket is designed to minimize noise, interconnect capacitance, and inductance, these effects can be further reduced by mounting the device directly on the PCB for production.



Altera recommends using the QFP development socket for prototyping only. Altera does not recommend using sockets for production.

Figure 4 shows the dimensions of the QFP development socket. Details A and B show the PCB pad layout length and width recommended for use with the development socket. These industry-standard pad layout dimensions are for the “gull-wing” lead that is typically found on QFP packages. The layout pad extends from 0.05 mm to 0.13 mm beyond each side of the lead width (A1), and 0.5 mm beyond each side of the lead length (A2), as shown in Details A and B, respectively. A layout pad of these dimensions is also suitable for use with QFP devices that do not use carriers. To ensure correct board layout, pad sizes must be compatible with the development socket and the QFP device leads.

Figure 4. QFP Development Socket Dimensions

Dimensions are shown in millimeters. The tolerance of all layout pad dimensions is ± 0.025 mm. The continuous duty rating for the development socket is -65°C to 155°C . The carrier and development socket are qualified to handle commercial and industrial operating temperatures.

Development Socket Length

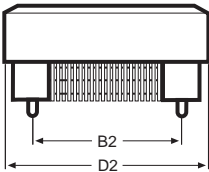

Development Socket Width

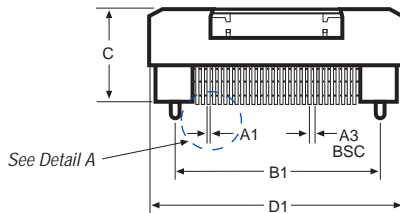

Detail A

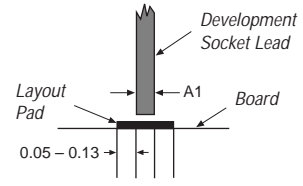

Recommended Board Layout

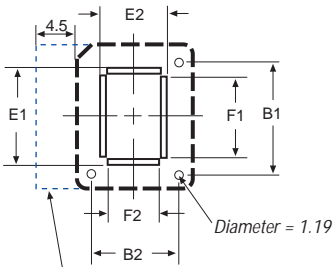

For 240- and 304-pin QFP packages, leave this space for removal of development socket lid.

Contact & Lid Detail

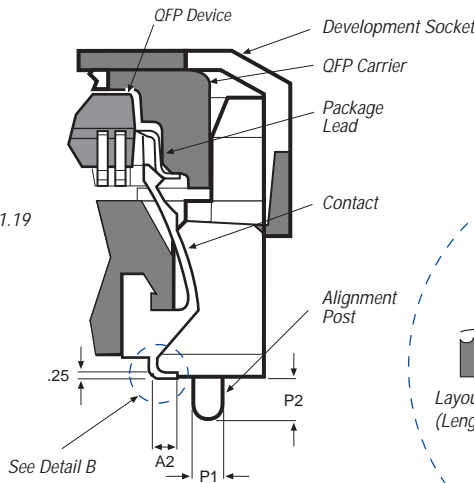

Detail B

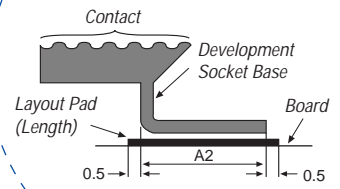

Pin Count	A1	A2	A3	B1	B2	C	D1	D2	E1	E2	F1	F2	P1	P2
100	0.20	0.93	0.65	25.00	19.00	12.00	31.51	25.54	23.63	17.63	18.85	12.35	1.00	1.50
160	0.20	0.93	0.65	33.80	33.80	12.80	39.80	39.80	32.08	32.08	25.35	25.35	1.00	1.50
208	0.20	0.93	0.50	33.82	33.82	12.80	39.80	39.80	31.68	31.68	25.50	25.50	1.00	1.50
240	0.20	0.93	0.50	34.00	34.00	14.30	44.00	42.90	35.20	35.20	29.50	29.50	1.00	1.50
304	0.20	0.93	0.50	42.00	42.00	14.30	52.00	50.90	43.30	43.30	37.50	37.50	1.00	1.50
Tolerance	± 0.12	± 0.12	± 0.12	± 0.12	± 0.12	± 0.40	± 0.20	± 0.20	± 0.12	± 0.12	± 0.12	± 0.12	± 0.12	± 0.12

The development socket base is designed to withstand the temperatures required by industry-standard solder reflow technology. The soldering time at the allowed maximum temperature of 220° C should be approximately 10 seconds. The soldering temperature should not increase more than 3° C per second.

To perform reflow operations, Altera recommends using 100% forced convection reflow ovens rather than infrared (IR) reflow ovens. The large thermal mass of the development socket base shields or “shadows” the solder paste from the IR radiation used in IR reflow ovens. Shadowing prevents the paste from heating and flowing properly. Improper heating and flowing of paste can cause inadequate lead contact with the circuit board and unacceptable solder joints. Ovens with 100% forced convection reflow provide the even and efficient heat transfer required to form an acceptable solder joint.



The development socket lid and the QFP carrier should not be subjected to the solder reflow process. They cannot withstand the typical reflow temperatures of 180° C to 220° C, and can be harmed by the cleaners and solvents used in the reflow process. Only the development socket base should be subjected to solder reflow. However, the socket lid and carrier are qualified to handle commercial and industrial operating temperatures.

With the appropriate solder mask, multiple development sockets can be closely spaced on the board. Three alignment posts ensure correct orientation and provide sufficient registration for reflow soldering. When other components must be placed near the development socket, the designer must make sure that component leads do not conflict with the outline of the development socket.

The socket lid holds the QFP carrier in the development socket base and braces the carrier by pressing the QFP device leads against the electrical contacts in the socket base. The contact material in the development socket base is beryllium copper with a tin/lead plating. These contacts connect the device leads to the PCB, ensuring a positive electrical connection that is not susceptible to mechanical interruption through jarring or impulsive shocks. The carrier design ensures that the pressure of the socket contacts does not significantly affect the coplanarity of the device leads. This carrier/socket combination allows the designer to perform mechanical analysis during the functional prototyping cycle.

Altera also provides a tool to extract the QFP device from the carrier. See [“Extracting a Device from the QFP Carrier” on page 745](#) of this data sheet for complete details.

Using the QFP Carrier & Development Socket

This section gives step-by-step instructions for the following procedures:

- Inserting the QFP carrier and device into the development socket
- Removing the QFP carrier and device from the development socket
- Programming a device in the QFP carrier
- Extracting a device from the QFP carrier



The device should be removed from the QFP carrier only after it has been programmed and is ready to be soldered onto the PCB.

Inserting the QFP Carrier & Device into the Development Socket

To insert a 100-, 160-, or 208- pin QFP carrier and device into the development socket:

1. Align the QFP carrier and device on the development socket by matching the beveled corner of the carrier to the beveled corner of the socket base and aligning the corresponding dots.
2. Place the QFP carrier and device in the development socket base.
3. Place the socket lid over the socket base and press down firmly on all four corners of the lid. Clicking sounds are clearly audible as the socket lid is pressed into place. See [Figure 5](#).
4. Visually confirm that the tabs on all sides of the lid have locked onto the development socket base.

Figure 5. Inserting a 100-, 160-, or 208-Pin QFP Carrier & Device into the Development Socket

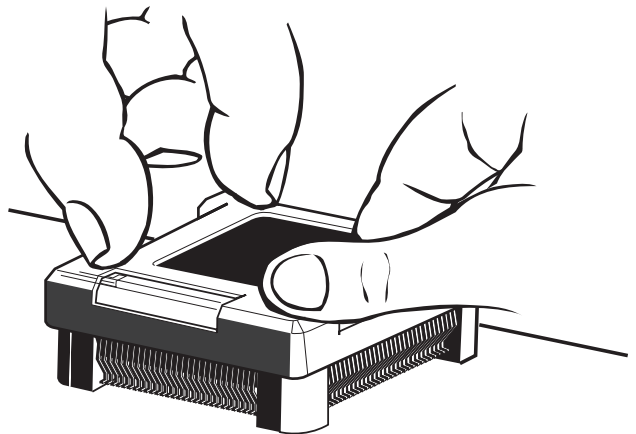



When placing the development socket lid onto or removing it from the socket base, Altera recommends bracing the side of the PCB opposite the development socket to prevent the PCB from flexing. Some insertion force is required to seat a high-pin-count device. If the PCB is not properly braced, repeated flexing of the PCB can cause excessive wear, resulting in cracks in the solder joints and in the PCB traces.

To insert a 240- or 304-pin QFP carrier and device into the development socket:

1. Align the QFP carrier and device on the development socket base by matching pin 1 of the device to pin 1 of the socket base.
2. Place the QFP carrier and device in the development socket base.
3. Align the development socket lid as shown in [Figure 6](#).

Figure 6. Aligning a 240- or 304-Pin QFP Development Socket Lid

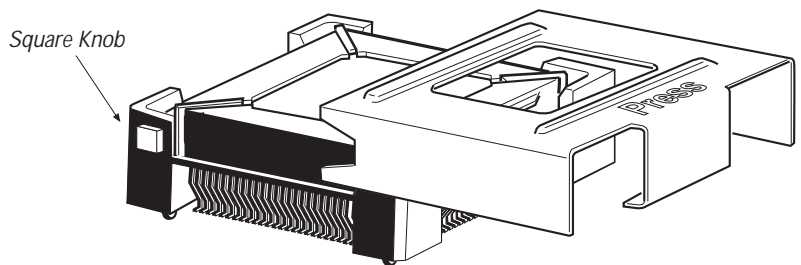

4. Slide the development socket lid horizontally on top of the development socket base until the lid reaches the square knobs on the sides of the socket base.
5. While pressing down on the part of the development socket lid labeled with the word “Press,” slide the development socket lid until the square knobs on the socket base fit firmly in the lid. See [Figure 7](#).

Figure 7. Sliding a 240- or 304-Pin QFP Development Socket Lid into Place

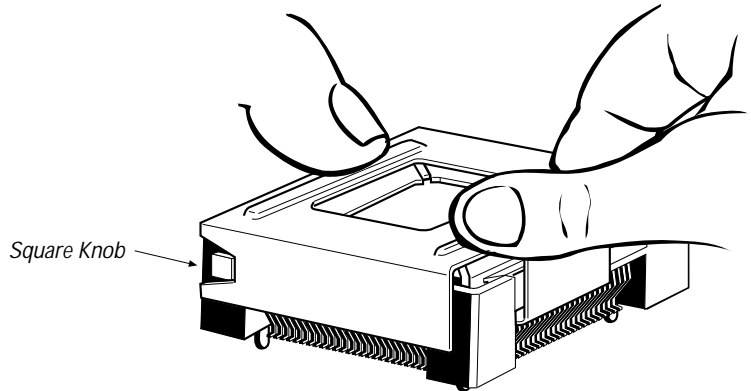

Removing the QFP Carrier & Device from the Development Socket

For 100-, 160-, 208-, 240-, and 304-pin packages, Altera does not recommend removing the development socket lid at temperatures below -10°C .

To remove a 100-, 160-, or 208-pin QFP carrier and device from the development socket:

1. Place the removal tool over the QFP socket lid, as shown in [Figure 8](#).
2. Gently press down, making sure that the edges of the tool fit into the slots on the top of the lid. Clicking sounds will be clearly audible. To ensure that all four tabs of the 160- and 208-pin QFP carrier have been unlatched from the development socket base, twist the removal tool back and forth after it is pressed down.
3. While maintaining pressure, lift the lid and removal tool together.
4. Remove the QFP carrier and device.



Altera recommends removing a QFP carrier and device from a development socket no more than 25 times.

Figure 8. Removing a 100-, 160-, or 208-Pin QFP Carrier & Device from the Development Socket

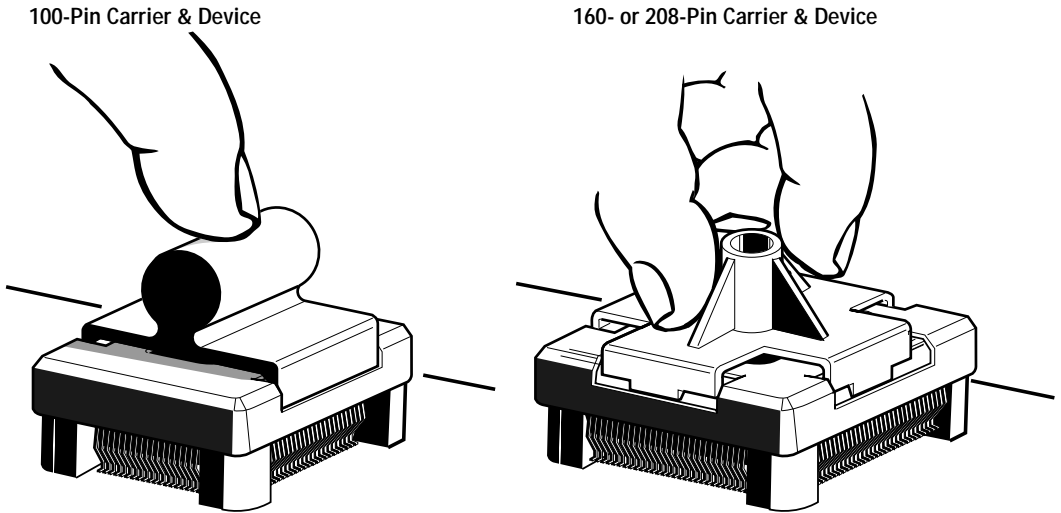

To remove a 240- or 304-pin QFP carrier and device from the development socket:

1. Place the lid removal tool in the slot between the edge of the development socket lid and the edge of the development socket base. See [Figure 9](#).

Figure 9. Removing a 240- or 304-Pin QFP Carrier & Device from the Development Socket

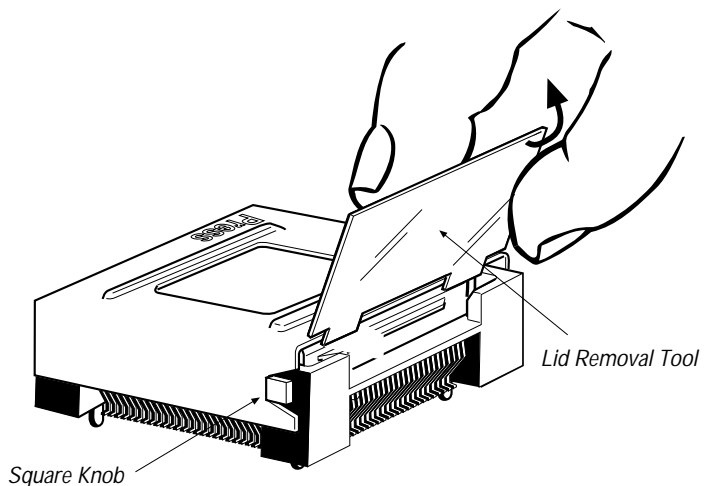

2. Tilt the top of the lid removal tool toward the center of the development socket until the development socket lid slides away from the square knobs on the sides of the socket base.
3. Remove the lid removal tool, slide the development socket lid back, and remove the lid from the development socket base.

Programming a Device in the QFP Carrier

QFP devices that are shipped in the protective QFP carriers are ready to be programmed with an Altera or third-party programming adapter. With Altera programming software and hardware, test vectors can be directly applied to the device for programming verification and functional testing. Devices in QFP packages can also be programmed with industry-standard programming hardware from other manufacturers.

To program a device in the QFP carrier:

1. Place the QFP carrier with the device into the programming adapter, making sure that the carrier and adapter are aligned correctly.
2. Close the retaining latch by pressing the latch against the socket. A clicking sound is clearly audible as the latch fastens over the socket.



The retaining latch on the clamshell-style programming adapter socket ensures good electrical contact between the device leads and the socket. To ensure proper programming, the retaining latch must be closed after the QFP carrier and device are placed into the programming adapter.

Extracting a Device from the QFP Carrier

Altera offers carrier extraction tools for 100-, 160-, 208-, 240-, and 304-pin devices, and recommends using the extraction tool to extract devices from QFP carriers. [Table 1](#) shows the ordering codes for QFP carrier extraction tools.

Product	Ordering Code
100-pin QFP carrier extraction tool	PL-EXT1
160- and 208-pin QFP carrier extraction tool	PL-EXT2
240-pin QFP carrier extraction tool	PL-EXT4
304-pin QFP carrier extraction tool	PL-EXT5

The QFP device fits in the QFP carrier extraction tool only when the device is correctly oriented in the carrier insertion slot. For 100-, 160-, and 208-pin QFP devices, the pin indicator on the corner of the device (as shown in [Figure 3](#)) should be aligned with the beveled corner of the extraction tool; a sliding platform slips over the QFP device, securing it in the slot and bending back the yellow retaining clips located on the corners of the QFP carrier.

For 240- and 304-pin QFP devices, the pin indicator on the corner of the device (as shown in [Figure 3](#)) should be aligned with the pin indicator on the extraction tool. The extraction tool lid closes over the QFP device, bending back the yellow retaining clips located on all four corners of the QFP carrier. The yellow retaining clips lock in the open position.

The extraction button on the extraction tool ejects the QFP device from the carrier and places the device directly onto a QFP handling tray or onto a catch plate, which is included with the extraction tool. The catch plate included with the extraction tool for 100-pin devices holds four devices; the catch plate included with 160-, 208-, 240-, and 304-pin devices holds two devices.

The ridges on the bottom of the extraction tool help to align the extraction tool with the sides of the handling tray or catch plate. The default size of the extraction tool supports the Peak Plastic Corporation low-profile JEDEC trays listed in [Table 2](#).

Pin Count	Peak Part Number
100	ND-1420-2.7-0611-8 Rev B
160	ND-2828-3.5-0308-8 Rev B
208	ND-2828-3.5-0308-8 Rev B
240	ND-3232-3.4-0308-6 Rev A
304	ND-4040-3.8-0206-8

A multi-device extraction tool is available for use in production environments. This tool extracts up to six QFP devices at a time into low-profile JEDEC trays. Contact Altera Customer Marketing at (408) 544-7104 for more information.

To extract a 100-, 160-, or 208-pin QFP device from the carrier using the extraction tool:

1. Align the ridges on the bottom of the extraction tool with the sides of an empty slot on the QFP handling tray. To ensure proper device orientation, align the beveled corner of the extraction tool with the beveled corner of the QFP handling tray. If a handling tray is not available, place the extraction tool over the catch plate provided.
2. Open the extraction tool by moving the sliding platform until the carrier insertion slot is completely exposed.
3. Place the carrier-protected QFP device into the carrier insertion slot. Align the beveled edge of the carrier with the beveled edge of the carrier insertion slot, and make sure that the carrier is flush with the platform base.
4. Move the sliding platform until it completely covers the QFP device. See [Figure 10](#).

Figure 10. Placing a 100-, 160-, or 208-Pin QFP Carrier & Device in the Extraction Tool

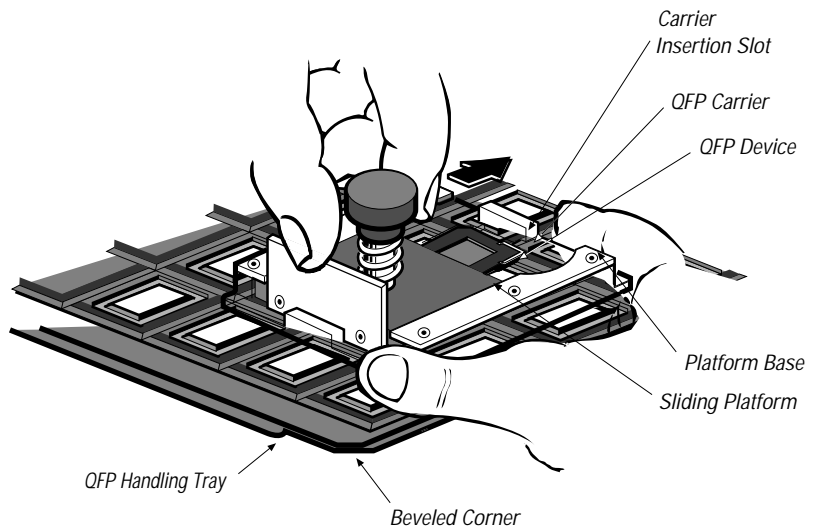

5. With the QFP device completely covered, press down on the extraction button to release the QFP device from the carrier. Place it in the QFP handling tray or on the catch plate. See [Figure 11](#). If a handling tray or a catch plate is not available, use a vacuum wand or other handling tool to move the QFP devices.

Figure 11. Pressing the Extraction Button to Remove a 100-, 160-, or 208-Pin QFP Device from the QFP Carrier

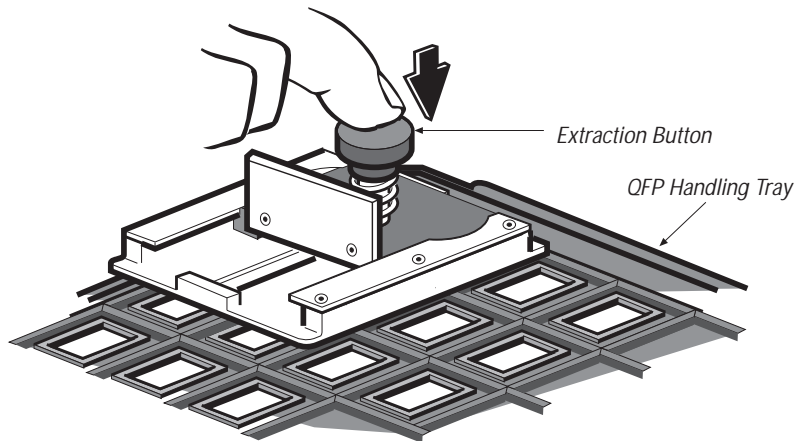

To extract a 240- or 304-pin QFP device from the carrier using the extraction tool:

1. Place the extraction tool over the QFP handling tray by lining up the ridges on the bottom of the extraction tool with the sides of an empty slot. To ensure proper device orientation, align the pin indicator on the extraction tool with the beveled corner of the QFP handling tray. If a handling tray is not available, place the extraction tool over the catch plate provided.
2. Open the extraction tool by lifting the lid upwards and back until the carrier insertion slot is completely exposed.
3. Place the carrier-protected QFP device into the carrier insertion slot. Align the pin indicator on the corner of the carrier with the pin indicator on the corner of the extraction tool.
4. Lower the extraction tool lid down until it is completely closed over the QFP device. See [Figure 12](#).

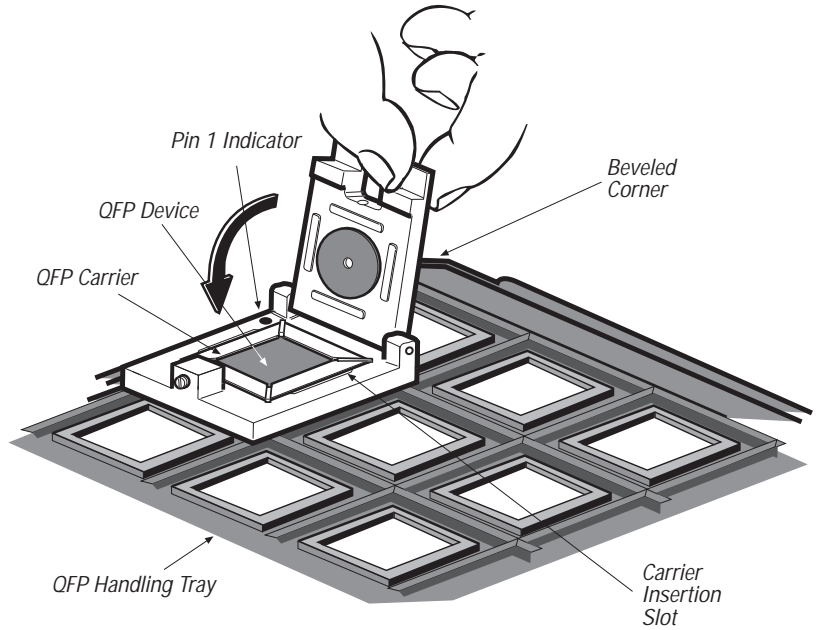
Figure 12. Placing a 240- or 304-Pin QFP Carrier & Device in the Extraction Tool

5. With the QFP device completely covered, press down on the extraction button to release the QFP device from the carrier and place it in the QFP handling tray or on the catch plate. If a handling tray or a catch plate is not available, use a vacuum wand or other handling tool to move the QFP devices.

Copyright © 1995, 1996, 1997, 1998 Altera Corporation, 101 Innovation Drive, San Jose, CA 95134, USA, all rights reserved.

By accessing this information, you agree to be bound by the terms of Altera's Legal Notice.